

[2.8]^{PM}

[3.6]^{PM}

CLASSIC



Brought to you by:
American PM Crane Imports Inc.
Phone# (877) MY-PM-CRANE
(877) 697-6272
Or# (407) 246-1642
Dealer Inquiries Welcome:
Email: Corplnq@PMCranes.Com



[elevate to the highest power]^{pm}

[2.8] PM

[3.6] PM

EN12999

EQUIPAGGIAMENTO DI SERIE - CONFIGURATION STANDARD EQUIPMENT - CONFIGURATION EQUIPEMENT STANDARD - SERIENMÄSSIG - EQUIPO DE SERIE



Cremagliera
Slewing by rack
Rotation avec crémaillère
Zahnstangenschwenkwerk
Rotación con cremallera



Martinetti stabilizzatori rotanti manuali
Manual flip up outriggers
Vérins pivotant manuellement
Manuell schwenkbare Abstützylinder
Brazos estabilizadores giratorios manuales



Bracci stabilizzatori a sfilo manuale
Manual pull-out outrigger booms
Bras stabilisateurs avec extension manuelle
Manuelle Abstützungen
Brazos estabilizadores a salida manual



Dispositivo automatico sicurezze stabilizzatori inserite
Safety Kit for outriggers
Dispositif de sécurité stabilisateurs
Sicherheitskit für die Abstützungen
Kit de Seguridad para estabilizadores



Blocco rotazione meccanico esterno
External mechanical slewing limiter
Limiteur de rotation mécanique extérieur
Externe Drehblockierung
Paro rotación mecánico externo

- 2 attivazioni in punta al braccio per l'utilizzo di accessori.
- 2 accessories can be fitted at boom tip.
- 2 activations a lapointe du bras pour l'utilisation d'accessoires.
- 2 Aktivationen am Ende des Arms für die Verwendung von Zubehör
- 2 conexiones en la punta de la grúa para accesorios

OPTIONAL



Scambiatore di calore
Oil cooler
Refroidisseur
Ölkühler
Enfriador de aceite



Avvolgitubo
Hose reel
Enrouleur pour activation
Umlenkrolle
Enrolladores



Serbatoio
Oil tank
Réservoir
Öltank
Depósito de Aceite



- Martinetti sfilo con passaggi olio interni
- Extension cylinders with internal oil flow
- Vérins Extension avec passage huile intérieur
- Ausziehzylinder mit internen Öldurchgängen
- Cilindros con pasaje de aceite interno

H1B3

CLASSE DI SOLLECITAZIONE A FATICA H1B3
FATIGUE-TESTED IN CLASS H1B3
ESSAIS EN FATIGUE EN CLASSE H1B3
ERMÜDUNGSTEST NACH KLASSE H1B3
COMPROBACIÓN DE FATIGA EN LA CLASE H1B3

[3]

3 ANNI DI GARANZIA SULLE PARTI STRUTTURALI
3 YEARS OF WARRANTY ON THE STRUCTURAL PARTS
3 ANS DE GARANTIE SUR LES PARTIES STRUCTURELLES
3 JAHRE GARANTIE AUF STRUKTURBAUTEILE
3 AÑOS DE GARANTÍA EN LAS PARTES ESTRUCTURALES

[IIA]

DICHIARAZIONE DI CONFORMITÀ DEL PRODUTTORE
DECLARATION OF CONFORMITY OF THE MANUFACTURER
DECLARATION DE CONFORMITE DU PRODUCTEUR
KONFORMITÄTSERKLÄRUNG DES HERSTELLERS
DECLARACIÓN DE CONFORMIDAD DEL PRODUCTOR

PQS

SISTEMA DI VERNICIATURA DI QUALITÀ CERTIFICATA
CERTIFIED PAINTING QUALITY SYSTEM
SYSTÈME DE PEINTURE DE QUALITÉ CERTIFIÉE
ZERTIFIZIERTES QUALITÄTS-LACKIERSYSTEM
SISTEMA DE BARNIZADO DE CALIDAD CERTIFICADA

Tutte le gru PM sono coperte da polizza assicurativa internazionale per la responsabilità verso terzi.
All PM Cranes are covered by international insurance policy for civil liability third party.
Toutes les grues sont couvertes par une police d'assurance internationale de responsabilité civile envers tiers.
PM Krane sind durch eine internationale Haftpflichtversicherung gegen Dritte abgesichert.
Todas las grúas PM cuentan con una póliza de seguros internacional contra las responsabilidades civiles hacia terceros.

OPTIONAL



- Limitatore di momento idraulico
- Hydraulic moment control device
- Limiteur de moment hydraulique
- Hydraulischer Momentbegrenzer
- Limitador de momento hidráulico



- Attacco accessorio
- Anchorage kit for accessories
- Kit attache accessoire
- Zubehörfestigungssatz
- Conexión accesorio

- Valvola di blocco rotazione
- Slewing valve block
- Soupape d'arrêt rotation
- Drehblockierungsventil
- Válvula de bloqueo rotación



- Attivazioni con avvolgi tubo
- Activation with hose reel
- Activation avec enrouleur
- Aktivationen mit Schlauchtrommel
- Activación con enrolladores



CLASSIC

[2.8] ^{PM}

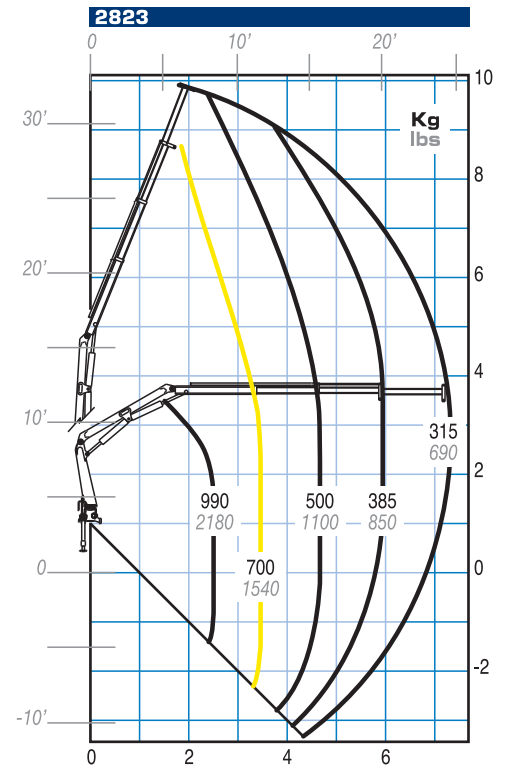
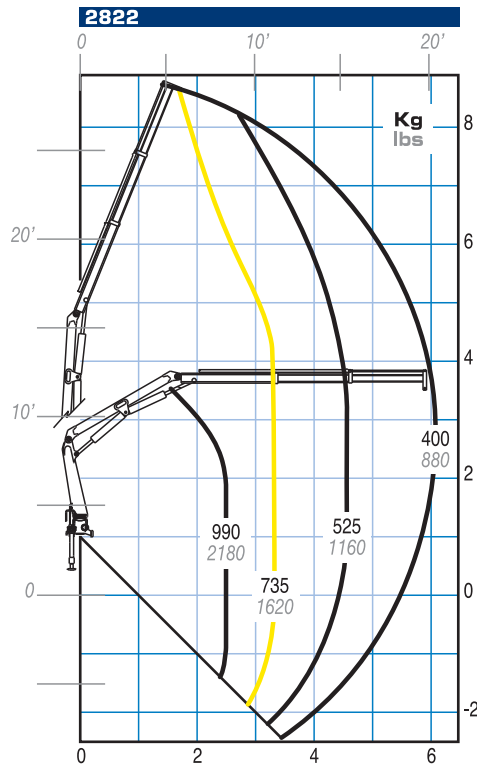
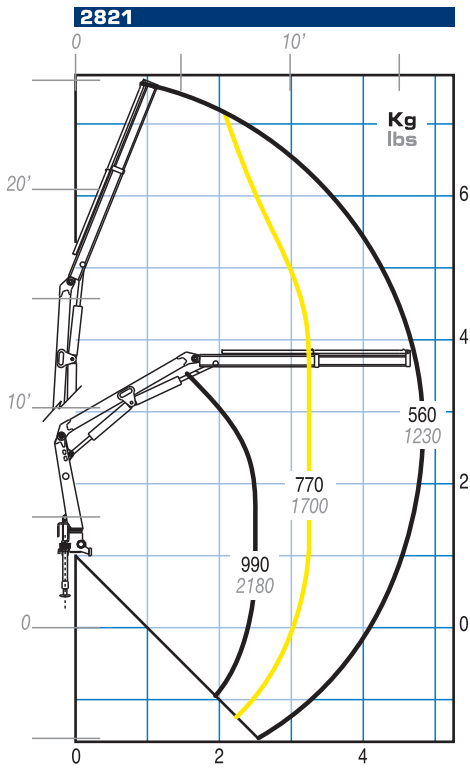

[3.6] ^{PM}

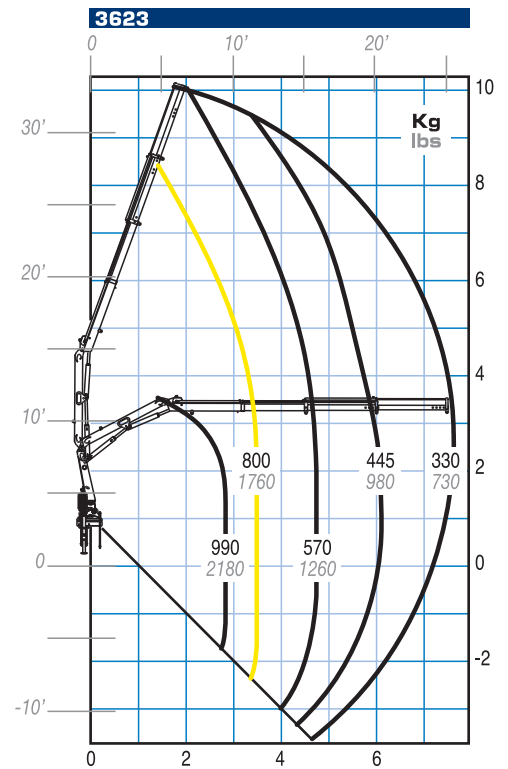
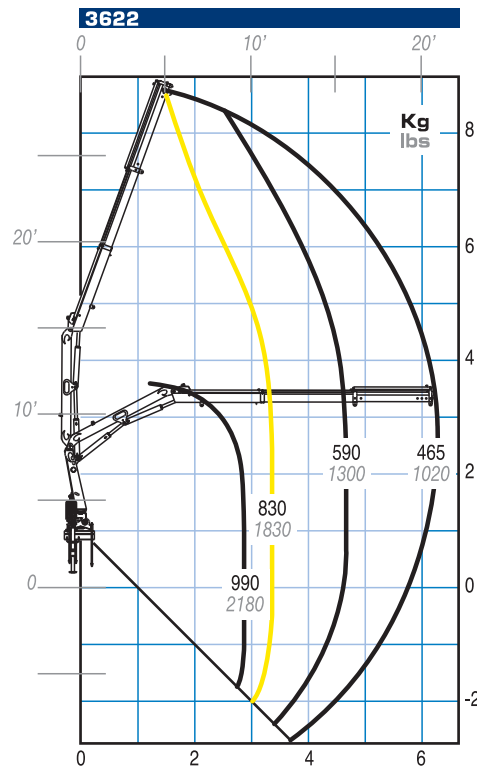
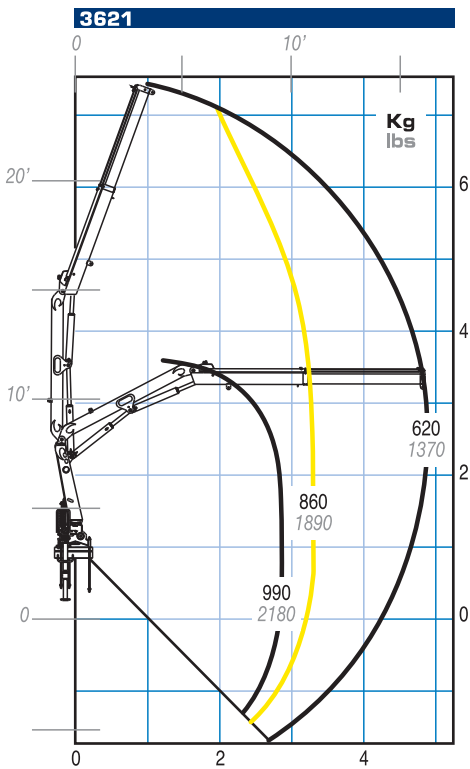

— Portata massima passante per l'orizzontale - Max. capacity from horizontal to vertical - Capacité maxi passant par l'horizontale
 Max. Tragkraft von horizontal bis zu vertical - Máxima capacidad de la horizontal a la vertical



[2.8] ^{PM}

[3.6] ^{PM}

mm
ft

[2.8] ^{PM}

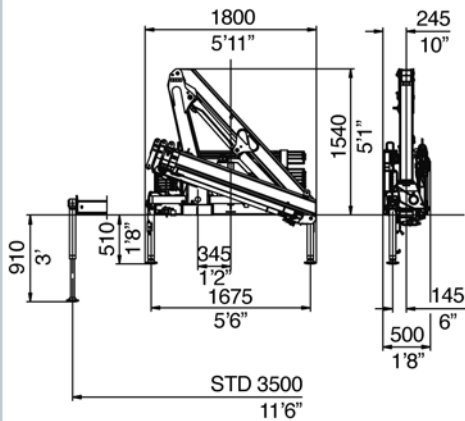

[3.6] ^{PM}

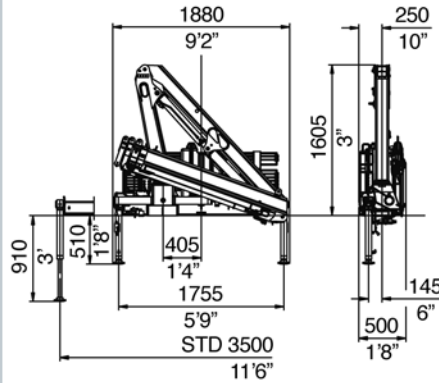

Abbinamento gru/veicolo
Trucking crane combination
Accouplement grue/véhicule
Kran zusammen mit LKW
Combinación grúa/camión

PTT/GVV	2,8	3,6
3,5 ton		
5,0 ton		
6,0 ton		
6,5 ton		
7,5 ton		
8,0 ton		
10,0 ton		
12,0 ton		
13,5 ton		
15,0 ton		
18,0 ton		
19,0 ton		
26,0 ton		
32,0 ton		



2 stabilizzatori STD
2 outriggers STD
2 stabilisateurs STD
2 Abstützungen STD
2 gatos de apoyo STD

PTT: Peso totale a terra - G.V.V. - P.T.A.C. - LKW Gesamtgewicht - Peso total del vehículo

		[2.8] ^{PM}			[3.6] ^{PM}		
		2821	2822	2823	3621	3622	3623
Momento di sollevamento massimo - Maximum lifting moment - Moment de levage maxi - Max. Lastmoment - Momento de elevación máxima	tm	2,5	2,4	2,4	2,9	2,9	2,8
	ft. lbs	18230	17540	17210	21150	20710	20250
Sbraccio oleodinamico - Maximum hydraulic reach - Allongement hydraulique Hydraulische Reichweite, Standard - Alcance hidráulico orizzontale - horizontal - horizontal - horizontal verticale - vertical - vertical - vertikal - vertical	m	4,70	6,10	7,50	4,90	6,30	7,65
	ft	15'5"	20'0"	24'7"	16'4"	20'8"	25'1"
	m	7,50	8,80	10,10	7,70	9,00	10,25
	ft	24'7"	28'10"	33'2"	25'3"	29'6"	33'8"
Sbraccio con prolunghe - Maximum reach with manual extensions - Allongement avec rallonges manuelles - Reichweite, manuelle Verlängerungen - Alcance con prolongas manuales orizzontale - horizontal - horizontal - horizontal verticale - vertical - vertical - vertikal - vertical	m	-	-	-	-	-	-
	ft	-	-	-	-	-	-
	m	-	-	-	-	-	-
	ft	-	-	-	-	-	-
Impianto oleodinamico - Hydraulic system - Circuit hydraulique - Hydraulikanlage - Sistema hidráulico portata raccomandata - recommended oil flow - débit recommandé - empfohlene Fördermenge - caudal requerido pressione massima - rated pressure - pression max - Betriebsdruck - presión máxima capacità del serbatoio - tank capacity - capacité du réservoir - Tankinhalt - capacidad del depósito de aceite	l/min	12	12	12	12	12	12
	gals/min	3	3	3	3	3	3
	Mpa	23	23	23	25	25	25
	Psi	3340	3340	3340	3630	3630	3630
	l	25	25	25	36	36	36
Gals	7	7	7	10	10	10	
Gruppo di rotazione - Slewing system - Rotation - Schwenksystem - Sistema de giro angolo di rotazione - slewing angle - angle de rotation - Schwenkbereich - ángulo de giro coppia di rotazione - slewing moment - couple de rotation - Schwenkmoment - momento de giro pendenza massima di lavoro - max. working heel - devers max de travail - max Arbeitsneigung - inclinación máxima de trabajo	°	360	360	360	360	360	360
	kNm	3,2	3,2	3,2	4,5	4,5	4,5
	ft. lbs	2360	2360	2360	3320	3320	3320
	%(°)	8,7(5)	8,7(5)	8,7(5)	8,7(5)	8,7(5)	8,7(5)
Peso della gru standard - Standard crane weight Poids de la grue standard - Eigengewicht - Peso de la grúa estandar Con serbatoio non rifornito - Empty oil tank - réservoir huile non garni - Leerer Öltank - depósito de aceite vacío	kg	395	425	450	425	455	480
	lbs	870	935	990	935	1005	1060

I dati tecnici possono essere aggiornati senza preavviso
Technical data can be revised without prior notice

Les données techniques peuvent être modifiées sans preavis

Technische Änderungen vorbehalten
Reservado el derecho de modificaciones

Robert's Diesel Works Inc. 906 West gore St. Orlando, Fl. 32805

407 246-1597